

CANGRAFT

ALPHA

SP 453

Range of our Fixed Tower Crane

MODEL	4510	5012	5030	5213	5510	6012	7022	7030	8030
Jib Length (m)	45	50	50	52	55	60	70	70	80
Max Capacity (t)	5	5	10	5	5	5	12	16	20

Auth. Dealer

CANGRAFT EQUIPMENT PRIVATE LIMITED
Office No.16, Wing C, Roshan One, Chakan M.I.D.C
Phase-II Near Podar International School
Varale, Pune-410501
Mobile : +91-8800239853, +91-8800495428
Email : info@cangraftequipment.com

alpha services

HEAD OFFICE

D-8/12, Phase-I
100 Feet Road,
Chatterpur Enclave,
New Delhi-110074

+91.11.26302647, 26302527
alpha@alphaservices.co.in

UNIT I

F-84-85, 85A & 59A,
RIICO Industrial Area,
Bhiwadi, Distt: Alwar,
Rajasthan-301019

+91.7231913111
alpha1@alphaservices.co.in

UNIT II

SPA-531,
RIICO Industrial Area,
Bhiwadi, Distt: Alwar,
Rajasthan-301019

+91.8875838111, 7230060714
+91.8875656111
alpha2@alphaservices.co.in



www.alphaservices.co.in

ADVANCED CRANES FOR CONSTRUCTION

A design of Braud & Fauchaux, France

MOBILE TOWER CRANE SP 453



MOBILE TOWER CRANE SP 453

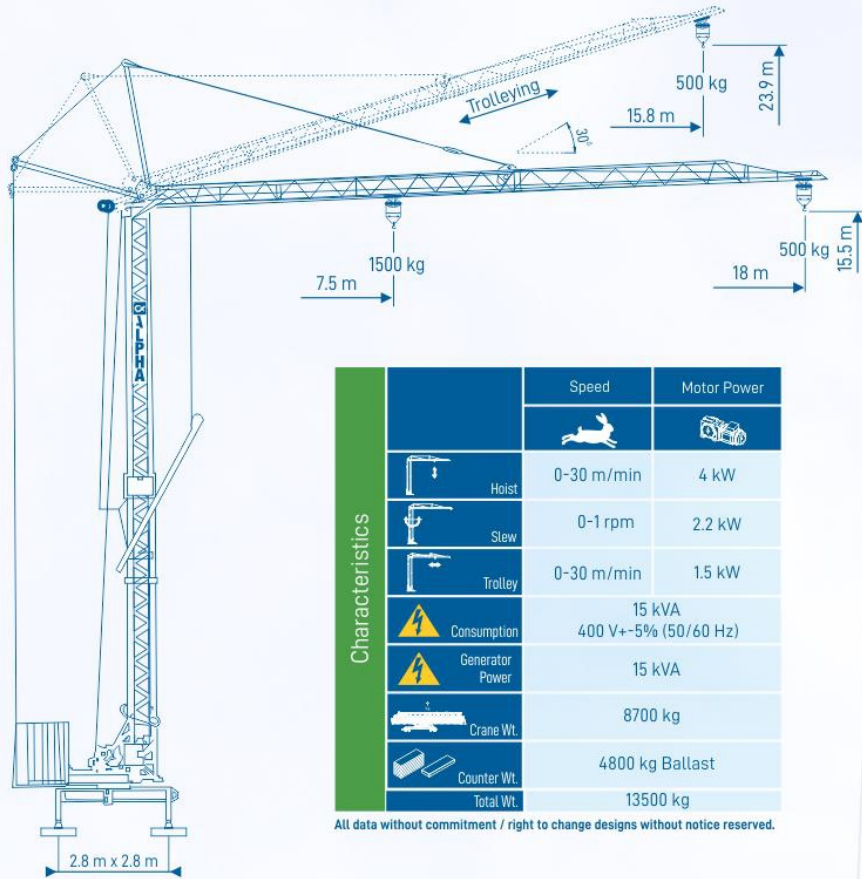

Characteristics	Speed	Motor Power
Hoist	0-30 m/min	4 kW
Stew	0-1 rpm	2.2 kW
Trolley	0-30 m/min	1.5 kW
Consumption	15 kVA	
Generator Power	400 V+5% (50/60 Hz)	
Crane Wt.	8700 kg	
Counter Wt.	4800 kg Ballast	
Total Wt.	13500 kg	

All data without commitment / right to change designs without notice reserved.

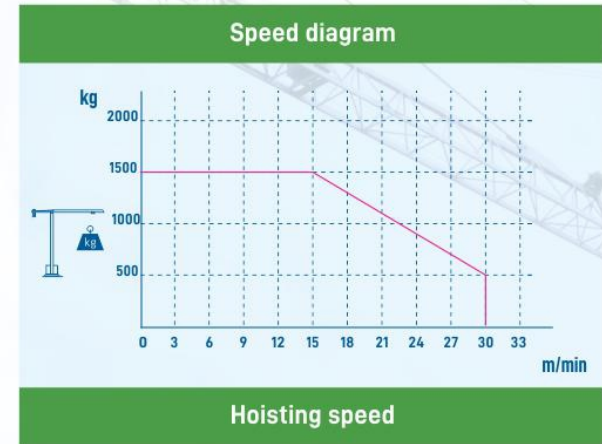
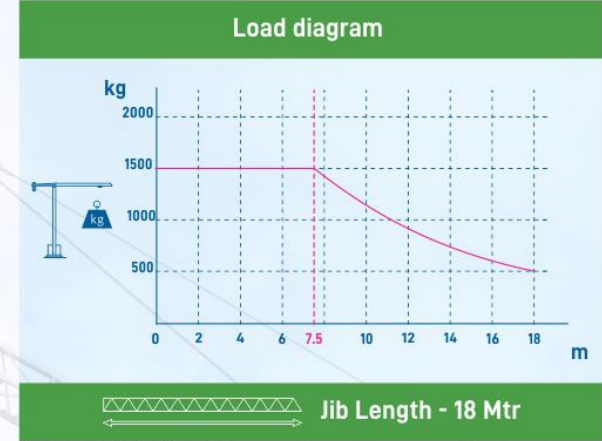
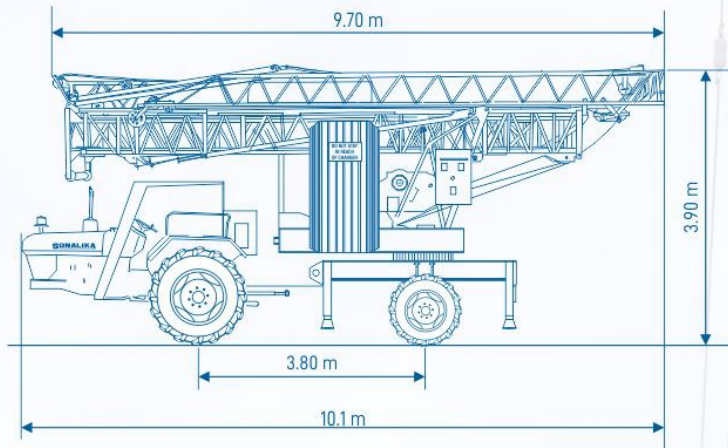

Salient Features of SP-453

- Self Propelled, All Terrain Crane
- Hydraulic Skid Steering System with articulated chassis for short turning radius.
- Built in alternator.
- Counterweight boxes for gravel ballast to minimize dead weight.
- Out and Down type stabilizers (Rack & Pinion).
- Remote Controlled Operations. Wireless remote control as option.
- Self folding & unfolding within few minutes.
- VVVF drive for hoisting performs jerk free operation.